



For a clean future



*Low NOx Burners*  
*Stork Thermeq*



## Why Stork Thermeq?

Stork Thermeq is an unrivalled specialist in the area of combustion systems. Our customers are refineries, power plants, industrial energy units and boiler manufacturers. Stork has over 60 years of experience in designing and supplying combustion installations for boilers with capacities between 10 and 2000 tonnes of steam per hour. Stork, as a designer of complete boiler installations

for power stations and industrial boilers, ensures a thorough insight in the requirements of the combustion installation for each situation. Our engineers fit patented and proven concepts to your specific demands. For many decades Stork Thermeq has a successful track record as Original Equipment Manufacturer for combustion systems.



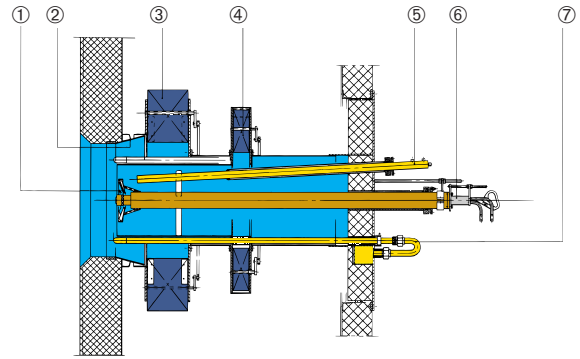
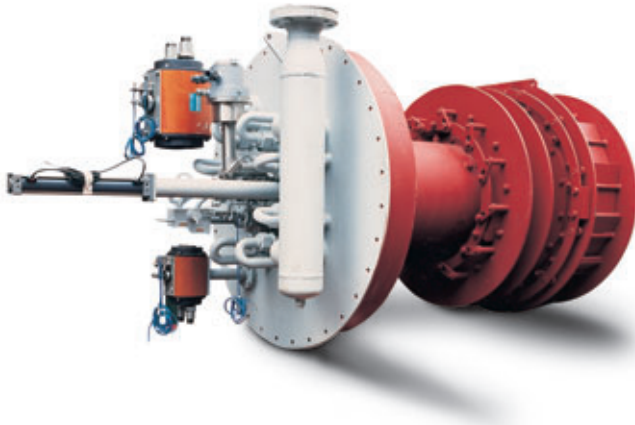

- ① STABILIZER
- ② BURNER THROAT
- ③ SEC. AIR REGISTER
- ④ PRIM. AIR REGISTER
- ⑤ IGNITION BURNER
- ⑥ OIL BURNER
- ⑦ GAS SPUD

## Double Register & Low Calorific Gas Burner

### General

Stringent environmental standards for emission of nitrogen oxides (NOx) have led to the development of the Double Register Burner. Based on thorough knowledge of NOx formation and experiments at test plants, Stork Thermeq developed a burner that enables a substantial cut back in NOx emissions, linked with a high combustion efficiency.

A typical feature of this burner type is the staged supply of combustion air. Part of the air is fed to the centre of the burner throat while being in strong rotation, while the rest of the air is skirting the flame like a peel. This type of air supply has the effect of falling flame temperature and oxygen concentration, which decreases the formation of thermal and fuel NOx.

### Low calorific gasses and waste streams

Besides the application of fuel oil and high calorific gasses, the Double Register concept can also be applied for all kind of Low Calorific Gasses and Waste streams, like for instance blast furnace gas, tail gas, coke oven gas and animal fat. The optimum results are obtained by a customer made design for each specific fuel or waste stream. Based on long term experience, Stork ensures a reliable burner for all kind of fuels and various applications

### Application

- Power station boilers
- Industrial boilers
- Waste heat recovery boilers
- Retrofit to low NOx

### Emissions

Application of the Double Register Burner leads to considerable reduction of NOx emission at combustion with low excess air. Unburned losses and CO remain at a minimum.

Technical data	
Gas:	natural gas refinery gas hydrogen gas process gas blast furnace gas tail gas vent gas
Oil:	light oil heavy oil residual oil bitumen, pitch animal fat bio oil
Heat input range: 5 - 100 MWth	
Guaranteed turn down ratio	
Gas:	1 : 5
Oil:	1 : 4

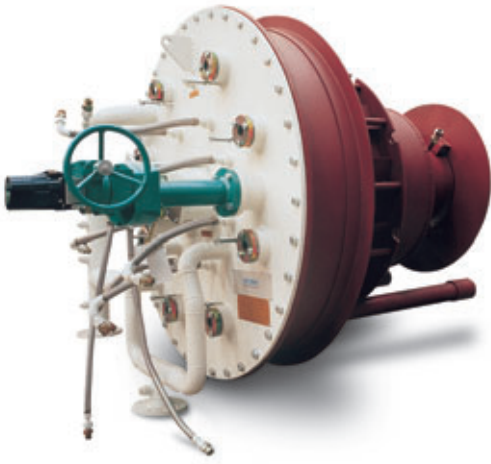

## Impulse Ultra Low NOx Gas Burner

### General

To meet the most stringent NOx requirements, the Impulse Gas Burner has been developed. Based on the experience with the Stork Double Register Burner and our thorough knowledge of the burning process and formation of NOx, we have developed our third generation gas burner, the Impuls Gas Burner. Single digit NOx values are possible.

### Combustion principle

The basic principle of the burner is the separated injection of air (1) and fuel (2) in the furnace. By means of this injection method flue gasses from the furnace (4) are aspirated into the air and gas flow prior to mixing the flows into a combustible mixture. The aspiration of flue gasses lowers the oxygen concentration and increases the mass flow in the flame, both limiting the formation of NOx. An impeller is installed in the centre of the air supply. In order to create a stable ignition of the flame (zone A), part of the fuel gas is injected after this impeller (3). The completion of combustion takes place in zone B at low excess air and low flame temperature conditions.

By using this unique technique Stork has achieved maximum NOx reduction with highly efficient combustion, complying with the most stringent requirements.

### Application

- Power Station boilers
- Industrial boilers
- Waste heat recovery boilers
- Retrofit to low NOx

### Emissions

The Impulse burner is able to meet the most stringent local and international NOx emission demands.

### Low NOx systems

Besides Low NOx burners, Stork Thermeq can offer Low NOx systems for new and retrofit installations like,

- two stage combustion
- flue gas re-circulation
- re-burning

The following emission levels can be achieved:

Fuel	NOx level
Natural Gas	10 mg/m <sub>0</sub> <sup>3</sup>
Heavy Fuel Oil	150 mg/m <sub>0</sub> <sup>3</sup>

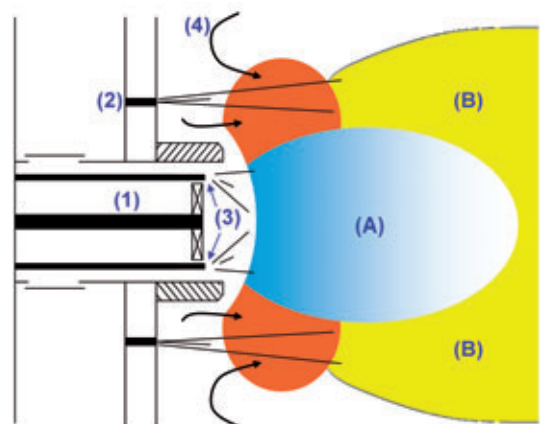

Technical data
Fuel: Gas
Heat input range: 5 - 100 MWth
Guaranteed turn down ratio: 1 : 5

# Process Control & Instrumentation

Our process control and instrumentation group consists of skilled and experienced personnel who are specialized in measurement, instrumentation, control, safe guarding and automation for a variety of burner and energy systems.

## Wide range of activities

### - Turnkey projects

Ranging from instrumentation to complete automation. From project management, engineering, delivery, erection, start up and training Stork Thermeq can do the job.

### - Renovation and updating

Stork Thermeq can offer you a complete renovation and updating of the process and control equipment. The degree of automation can also be improved by the use of intelligent systems and modern field equipment, tailored to your specific requirements.

### - Energy audits / Consultancy

Our specialists and facilities can execute energy audits to investigate and review processes in existing energy systems and advise you on further improvements.

## A practical project oriented approach

Projects and orders are carried out using a proven project approach. Unique is the combination of activities of the process and control & instrumentation group.

- Energy Audits
- Consultancy / Studies
- Basic and detail engineering
- BMS, DCS and & PLC /Scada systems
- Instrumentation and Emergency Shut Down (ESD) systems
- System verification / Factory Acceptance Test (FAT)
- Commissioning / Site acceptance Test (SAT)
- Training

## A strong service group

Stork Thermeq has a strong service group at its disposal, which aims at maintaining the reliability of installations with a minimum possible operating cost. Five important factors contribute to this:

- Planned preventive maintenance and regular inspections
- Reconditioning and supply of spare parts
- Trouble shooting
- Training
- Emission and energy measurements



## Qualifications

Stork Thermeq BV is certified according to:

- ISO 9001 (2000).



- European Pressure Equipment Directive



- ASME certificates and Code Stamps S , U and R
- VCA\*\*
- TÜV, AD-Merkblätter HP 0 and TRD 201



Furthermore, Stork Thermeq is qualified for designing, manufacturing, servicing and testing boiler components and pressure vessels to the internationally recognised rules and requirements of:

- Dutch Rules for Pressure Vessels
- UDT Office of Technical inspection, Poland
- Other Codes and standards as PD 5500, EN 13445, SVTI/ ASIT, IBR, CODAP, etc

Welders and welding procedures are available for any possible steel type and procedure combinations, such as prescribed by Euronorm and ASME.

## The Stork Network

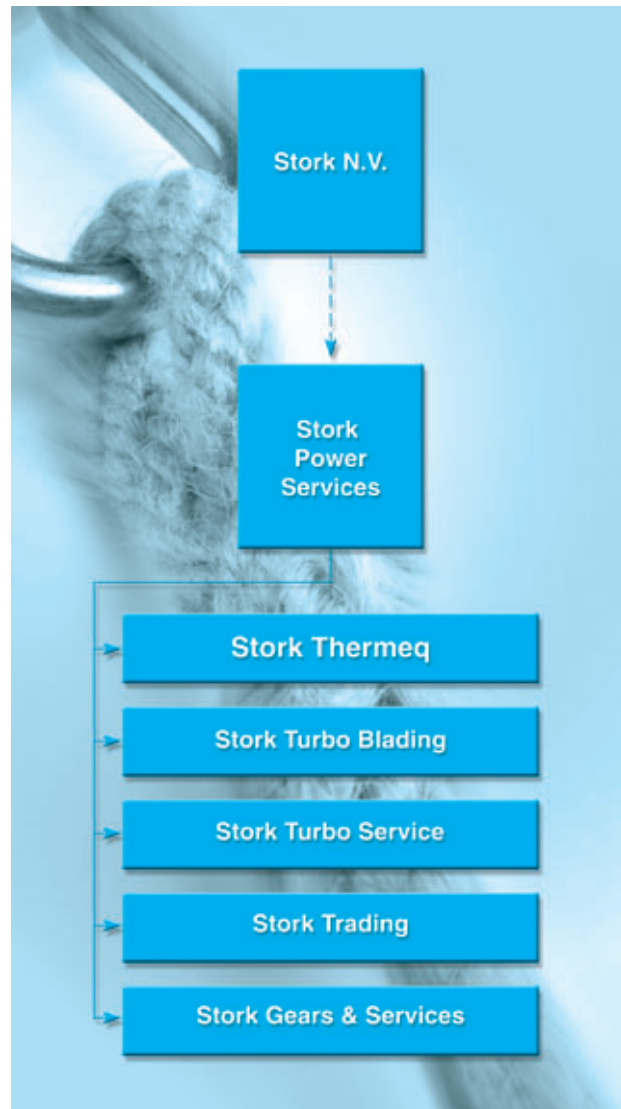

Stork Thermeq  
P.O. Box 33  
7550 AA Hengelo (Ov.)  
The Netherlands

Visiting address:  
Langelernmaatweg 12  
7553 JD Hengelo (Ov.)  
The Netherlands  
Tel: +31 (0)74 240 1724  
Fax: +31 (0)74 242 4790

e-mail: [info.thermeq@stork.com](mailto:info.thermeq@stork.com)  
website: [www.thermeq.nl](http://www.thermeq.nl)